

0~+5W Positive power tolerance | 20,97% Maximum efficiency



## JNL SOLAR, A HIGH-QUALITY MODULE THROUGH ITS HIGH PERFORMANCE CONSTRUCTION

Extensive experience in technology, constant innovation and sustainable optimisation form the basis for the performance of our high-quality modules. JNL Solar carries out all stages of construction at its production site, enabling us to guarantee our customers the highest quality in every step, from assembly to finishing.

Our modules are extremely versatile in their use. They offer suitable solutions for any installation and sustainable performance around the world..



Additional efficiency and easy maintenance thanks to the highly transparent self-cleaning glass.



A neat and elegant design, for a perfect integration on the roof.



Long-term safety and top performance guaranteed. 25 year performance guarantee and 25 year product guarantee.



High reliability through rigorous quality control. More than 30 internal tests (UV, HF, and many others). Our tests go beyond certification requirements.



PID resistance and hotspot protection verified and rigorously produced.



Ideal for private or commercial installations. High power reduces installation costs.



High conversion efficiency through high quality modules and advanced cell technology.



Front panel with anti-reflective coating.



Our panels are tested and certified to withstand extreme environmental conditions: wind loads (2400 Pa) and snow loads (5400 Pa).

## MECANICAL DATA

Dimensions	1724 mm x 1134mm x 30mm (with frame)
Weight	21,5 kg
Solar Cells Type	Monocrystal Silicon 182mm x 91mm-10BB
Glass	3,2mm
Frame	Anodized Aluminium Alloy
Junction Box	IP68
Cables	4mm <sup>2</sup> , 1100mm
Connector	MC4 Compatible
Wind/Snow Load	≤ 5400 Pa

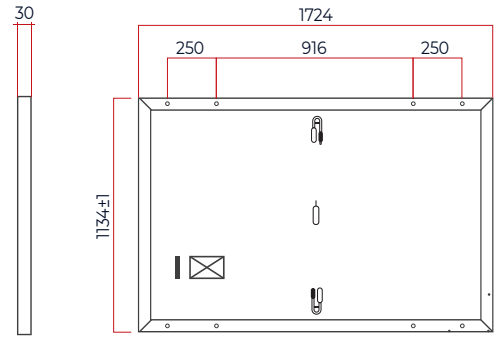

## ELECTRICAL DATA

POWERS CLASSES		390	395	400	405	410
Peak Power	$P_{max}$	390	395	400	405	410
Open Circuit Voltage	$V_{oc}$	36,53	36,73	36,93	37,13	37,33
Max. Power Voltage	$V_{mpp}$	30,41	30,62	30,83	31,04	31,25
Short Circuit Current	$I_{sc}$	13,62	13,69	13,76	13,83	13,90
Max. Power Current Imp	$I_{mp}$	12,83	12,90	12,98	13,05	13,12
Module Efficiency		19,95%	20,20%	20,46%	20,72%	20,97%
Power Tolerance		0~+5W				
Max. System Voltage		DC 1500V (TUV) / 1000V (UL)				
Max. Series Fuse Rating		25A				

STC : Irradiance 1000W/m<sup>2</sup>, 25°C, AM 1.5

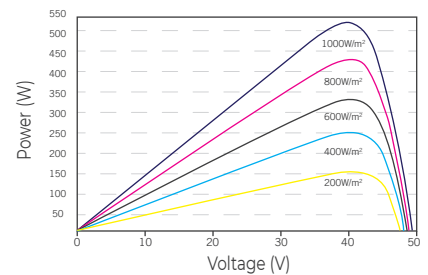
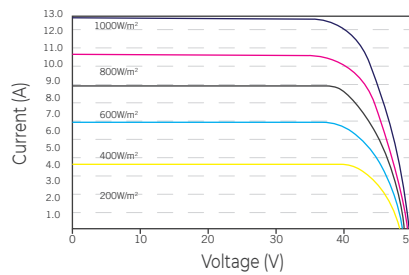
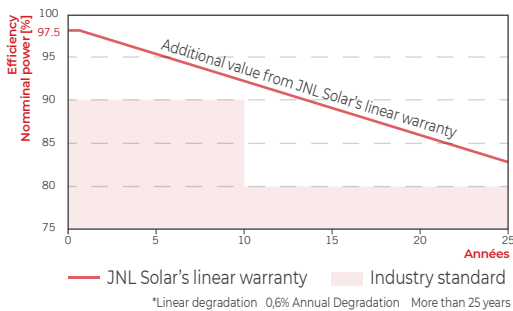

## TEMPERATURE RATINGS

Temperature Coefficient of Isc	0.048%/°C	Operational Temperature	-40±85°C
Temperature Coefficient of Voc	-0.27%/°C	NOCT (Nominal Operating Cell Temperature)	44±2°C
Temperature Coefficient of Pmax	-0.35%/°C		

## PACKAGING CONFIGURATION

Conteneur	40 HQ
Quantité / palette	36 pieces
Palettes / Conteneur	26 pieces
Quantité / conteneur	936 pieces

## AUTHORIZED DEALER

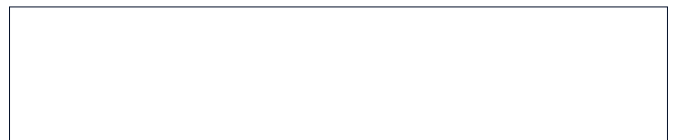

## CERTIFICATIONS



IEC 61215-1:2016 - IEC 61215-1-1:2016 - IEC 61215-2:2016 - IEC 61730-1:2016 - IEC 61730-2:2016 - EN 61215-1:2016 - EN 61215-1-1:2016 - EN 61215-2:2017 - EN IEC 61730-1:2018 - EN IEC 61730-1:2018/AC:2018-06 - EN IEC 61730-2:2018 - EN IEC 61730-2:2018/AC:2018-0

**CAUTION:** Read the instructions for safety installations before using the product JNLSolar (All rights reserved) © 2022. Specifications included in this data sheet are subject to change without notice.